



Installing the Dialogic® Brooktrout® TruFax® Analog PCI Board

Part Number: 931-128-05

The Dialogic® Brooktrout® TruFax® Analog PCI board is a half-sized, single-slot, PCI-bus compatible fax processing board (“TruFax®” or TruFax® board(s)”). This board provides the following:

- ◆ On-board analog connections
- ◆ One or two V.17 fax channels per board

This installation guide provides information on:

- ◆ Safety Compliance Statements
- ◆ System Requirements (including telephone service)
- ◆ Setting the Module Number
- ◆ Installing the Dialogic® Brooktrout® TruFax® Board
- ◆ Recognizing PCI Slots
- ◆ Connecting the Phone Service
- ◆ Understanding LED Signals
- ◆ Using the Dialogic® Brooktrout® TruFax® Analog Board
- ◆ Getting Help

Safety Compliance Statements

- ◆ Install this board only in UL Listed equipment that has instructions stating that the user may install and remove accessory boards.
- ◆ Disconnect any TNV circuit connectors (telephone line cords) from this board before removing the cover of the equipment.

System Requirements

This board must be installed in an enclosure that meets the following specifications.

Note: Your TruFax® Analog board can coexist in the same chassis with a maximum of three other TruFax® or TR1000 boards. If the software detects more than three other TruFax® or TR1000 boards in the same chassis, any TruFax® Analog board that exceeds the limit of four boards will not operate.

Your TruFax® Analog board cannot coexist in the same chassis with other TR1034 boards or SR140 virtual modules. If the software detects a TR1034 or SR140 module in the chassis, only the TR1034 and SR140 modules will continue to operate.

- ◆ A Pentium or later host processor
- ◆ An available 33 or 66 MHz, 32- or 64-bit PCI bus slot. See [Recognizing PCI Slots](#) for more information.

The TruFax® Analog PCI Series boards can be used in either 3.3V or 5V signaling PCI slots.

- ◆ Temperature: 0° C - 50° C
- ◆ Humidity: 10% - 95% (non-condensing)
- ◆ Power Requirements:

Board	+5V	+3.3 V	Total Power
1 channel	0.3A	1.0A	4.8 W
2 channels	0.3A	1.0A	4.8 W

The following telephone service is also required:

- ◆ Analog loop start interface

Setting the Module Number

Set each board to a unique module number to easily identify the resources associated with a specific board in a multi-board system.

Use the SW-1 rotary switch to set a unique module number for each Dialogic® Brooktrout® board. See Figure 4 for the switch location. Select a number from 2 - 9 on the rotary switch. Settings 0 and 1 are reserved and cannot be used.

Installing the Dialogic® Brooktrout® TruFax® Board

To install your board:

1. Turn off your PC and remove the cover.



Caution: A small amount of static electricity can destroy the sensitive components on your board. To prevent static damage, always connect yourself to ground using a ground strap before touching a circuit board. Handle boards only by the edges or metal mounting brackets and transport boards in an anti-static bag.

2. Locate a free PCI bus slot, and remove the slot cover.
3. Carefully align the board with the slot and firmly seat the board into the slot.
4. Tighten the mounting bracket screw to secure the board to the chassis.



Warning: When installing the board, be sure that the mounting bracket is securely fastened to the chassis and the chassis is plugged into a grounded three prong plug. Improper chassis or bracket grounding can result in harmful or fatal electrical shock as well as component damage.

5. Replace the cover.
6. Turn on your computer.

Note: Dialogic® Brooktrout® boards should not be present in the computer during the installation of any operating system. The operating system might misinterpret the board as being some other device, with unpredictable consequences.

Recognizing PCI Slots

The PCI slots in the computer chassis usually appear as white slots. The Dialogic® Brooktrout® TruFax® Analog board can be inserted into any of the PCI slots shown in Figure 1.

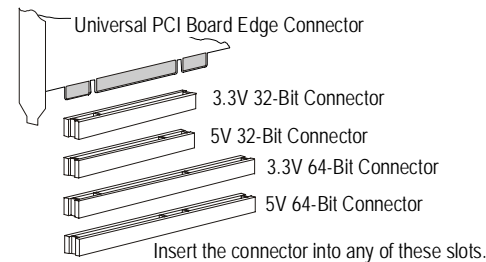

Figure 1. PCI Slots

Connecting the Phone Service

The appropriate telephone service and hookups must be installed at your site in order to connect to telephone service. The following table shows the relationship between channel and connector.

Channel Number	RJ-45 Connector	Type of Service
0	A	Analog Loop Start
1	A	Analog Loop Start

Use the cable supplied with the board. See Figure 2 for pinout details for your board.

Use the following instructions to connect your board to Analog service:

1. Plug one end of the cable into the RJ-45 telephone connector on the board (see Figure 3 to locate connector).
2. Plug the other end into the wall connector for your telephone service.

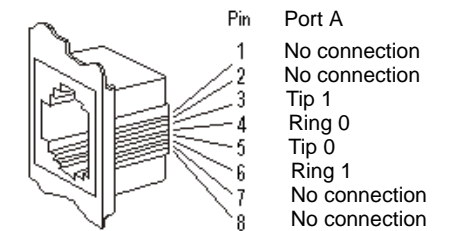

Figure 2. Analog Loop Start Connector Pinouts

Understanding LED Signals

LEDs on the Mounting Bracket

The LEDs on the mounting bracket provide information about the status of the different systems on the board. To identify and locate these LEDs, see Figure 3.

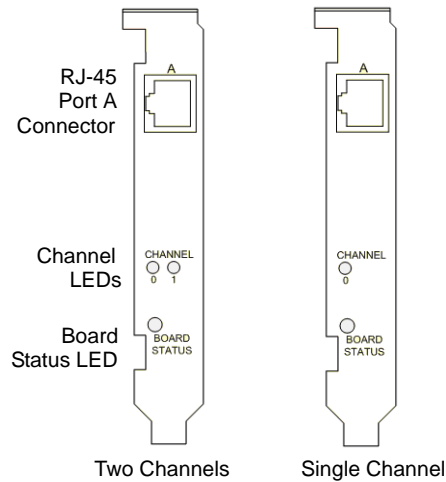

Figure 3. End Panel Connector and LEDs

The following tables describe how the end panel LEDs provide information:

Channel LEDs

Channel LEDs	Meaning
Off	Channel is on hook (inactive).
Flashing at 0.5 second rate	Channel is off hook (active).
Flashing at Ring Cadence (varies by country)	Incoming ring signal.

Board Status LED

Board Status LED	Meaning
Flashing yellow (1.5 second rate)	Board has successfully powered up and is ready for firmware.
Steady red	Board has failed power up tests.
Flashing yellow and green	Application is downloading firmware to the board.
Flashing green (1 second rate)	Firmware is downloaded, and the board is in service.
Off	Board is not powered up.

Using the Dialogic® Brooktrout® TruFax® Analog Board

Once you have installed the TruFax® Analog board, install and configure your fax software application according to instructions included with the software.

Getting Help

Dialogic provides technical support for customers who have purchased hardware or software products from Dialogic. If you purchased products from a reseller, please contact that reseller for technical support. This equipment contains no user serviceable parts and is not intended for repair by unauthorized personnel. If you experience problems with the TruFax® Analog board, for repair or warranty information, please use the web site below for technical support. If the equipment is causing harm to the telephone network, the telephone company might request that you disconnect the equipment until the problem is resolved.

www.dialogic.com/support

Copyright and Legal Notice

Copyright © 2006-2008 Dialogic Corporation. All Rights Reserved. You may not reproduce this document in whole or in part without permission in writing from Dialogic Corporation at the address provided below.

All contents of this document are subject to change without notice and do not represent a commitment on the part of Dialogic Corporation or its subsidiaries. Reasonable effort is made to ensure the accuracy of the information contained in the document. However, due to ongoing product improvements and revisions, Dialogic Corporation and its subsidiaries do not warrant the accuracy of this information and cannot accept responsibility for errors or omissions that may be contained in this document.

INFORMATION IN THIS DOCUMENT IS PROVIDED IN CONNECTION WITH DIALOGIC® PRODUCTS. NO LICENSE, EXPRESS OR IMPLIED, BY ESTOPPEL OR OTHERWISE, TO ANY INTELLECTUAL PROPERTY RIGHTS IS GRANTED BY THIS DOCUMENT. EXCEPT AS EXPLICITLY SET FORTH BELOW OR AS PROVIDED IN A SIGNED AGREEMENT BETWEEN YOU AND DIALOGIC, DIALOGIC ASSUMES NO LIABILITY WHATSOEVER, AND DIALOGIC DISCLAIMS ANY EXPRESS OR IMPLIED WARRANTY, RELATING TO SALE AND/OR USE OF DIALOGIC PRODUCTS INCLUDING LIABILITY OR WARRANTIES RELATING TO FITNESS FOR A PARTICULAR PURPOSE, MERCHANTABILITY, OR INFRINGEMENT OF ANY INTELLECTUAL PROPERTY RIGHT OF A THIRD PARTY.

Dialogic products are not intended for use in medical, life saving, life sustaining, critical control or safety systems, or in nuclear facility applications.

It is possible that the use or implementation of any one of the concepts, applications, or ideas described in this document, in marketing collateral produced by or on web pages maintained by Dialogic Corporation or its subsidiaries may infringe one or more patents or other intellectual property rights owned by third parties. Dialogic Corporation or its subsidiaries do not provide any intellectual property licenses with the sale of Dialogic products other than a license to use such product in accordance with intellectual property owned or validly licensed by Dialogic Corporation or its subsidiaries. More detailed information about such intellectual property is available from Dialogic Corporation's legal department at 9800 Cavendish Blvd., 5th Floor, Montreal, Quebec, Canada H4M 2V9. The software referred to in this document is provided under a Software License Agreement. Refer to the Software License Agreement for complete details governing the use of the software.

Dialogic Corporation encourages all users of its products to procure all necessary intellectual property licenses required to implement any concepts or applications and does not condone or encourage any intellectual property infringement and disclaims any responsibility related thereto. These intellectual property licenses may differ from country to country and it is the responsibility of those who develop the concepts or applications to be aware of and comply with different national license requirements.

Dialogic, Dialogic Pro, Brooktrout, Cantata, SnowShore, Eicon, Eicon Networks, Eiconcard, Diva, SIPcontrol, Diva ISDN, TruFax, Realblocs, Realcomm 100, NetAccess, Instant ISDN, TRXStream, Exnet, Exnet Connect, EXS, ExchangePlus VSE, SwitchKit, N20, Powering The Service-Ready Network, Vantage, Connecting People to Information, Connecting to Growth and Shiva, among others as well as related logos, are either registered trademarks or trademarks of Dialogic.

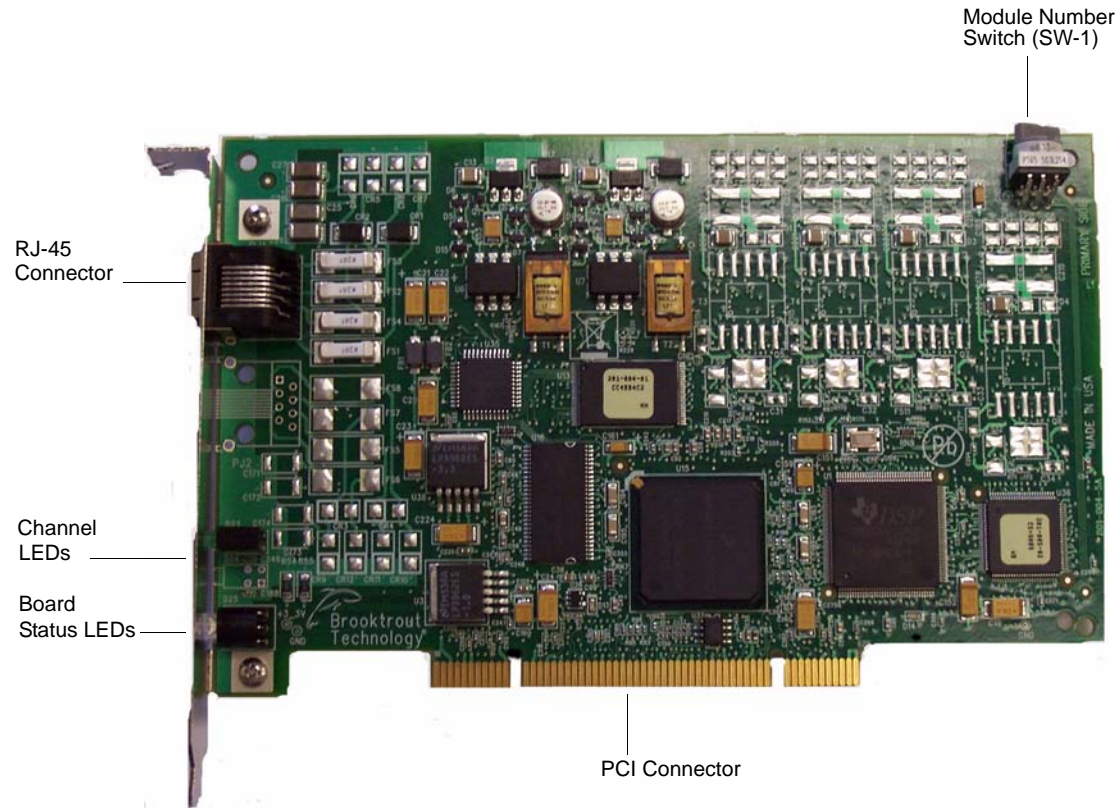

Figure 4. Dialogic® Brooktrout® TruFax® Analog PCI Series Board