

# Dialogic

## Installing the Dialogic® Brooktrout® TR1034 DID, Combo, & Loop Start PCI Express Board

Part Number: 931-165-05

The Dialogic® Brooktrout® TR1034 Analog Loop Start (ALS), Analog Direct Inward Dialing (DID), or combination ALS/DID PCI Express board (“TR1034” or “TR1034 board(s)”) is a half-sized, single-slot, PCI Express-bus compatible fax board. This board provides the following:

- ◆ On-board analog connections
- ◆ V.34 transmission speed for ALS. V.17 for DID
- ◆ Up to four fax or voice channels per board

This series of boards are single lane (x4 mechanical form factor) cards.

This installation guide provides information about:

- ◆ Safety Compliance Statements
- ◆ System Requirements (including telephone services)
- ◆ Setting the Module Number
- ◆ Installing the Board
- ◆ Recognizing PCI Express Slots
- ◆ Connecting the Phone Service
- ◆ Understanding LED Signals
- ◆ Using the TR1034 DID, Combo & Loop Start Board
- ◆ Getting Help

## Safety Compliance Statements

- ◆ Install this board only in UL Listed equipment that has instructions stating that the user may install and remove accessory boards.
- ◆ Disconnect any telephone cords from the board before removing the chassis cover of the equipment.
- ◆ Models of this board that contain DID interfaces are for use only in equipment that has a permanent connection to protective earth and is installed in a restricted access location.

## System Requirements

This board must be installed in an enclosure that meets the following specifications:

- ◆ Chassis Requirement: Compliant to the PCI Express Base Specification, Rev 1.1
- ◆ A Pentium or later host processor
- ◆ A PCIe x4, x8, or x16 bus slot. See [Recognizing PCI Express Slots](#) for more information.
- ◆ Temperature: 0° C - 50° C
- ◆ Humidity: 10% - 95% (non-condensing)
- ◆ Power Requirements:

Board	Total Power at 12 V
Combination 2 ALS and 2 DID Channels	15 W
2 ALS Channels	12 W
4 DID Channels	17 W

One or both of the following telephone services are also required:

- ◆ Analog loop start interface for ALS port
- ◆ Analog direct inward dialing interface for DID ports (Do not mix ALS and DID lines and ports)

## Setting the Module Number

Set each board to a unique module number to easily identify the resources associated with a specific board in a multi-board system.

Use the SW-1 rotary switch to set a unique module number for each Dialogic® Brooktrout® board. See Figure 4 for the switch location. Select a number from 2 - F on the rotary switch. Settings 0 and 1 are reserved and cannot be used.

## Installing the Board

To install your board:

1. Turn off your PC and remove the cover.



Caution: A small amount of static electricity can destroy the sensitive components on your board. To prevent static damage, always connect yourself to ground using a ground strap before touching a circuit board. Handle boards only by the edges or metal mounting brackets and transport boards in an anti-static bag.

2. If the system has a PCI Express expansion hold-down bar, remove it.
3. Locate a free PCI Express bus slot that is x4 or larger.
4. Carefully align the board with the slot and firmly seat the board into the slot.
5. Tighten the mounting bracket screw to secure the board to the chassis.



Warning: When installing the board, be sure that the mounting bracket is securely fastened to the chassis and the chassis is plugged into a grounded three prong plug. Improper chassis or bracket grounding can result in harmful or fatal electrical shock as well as component damage.

6. Replace the cover.
7. Turn on your computer.

**Note:** Dialogic® Brooktrout® boards should not be present in the computer during the installation of any operating system. The operating system might misinterpret the board as being some other device, with unpredictable consequences.

## Recognizing PCI Express Slots

The PCI Express slots in the computer chassis usually appear as white slots. Your board can be inserted into any of the PCIe slots shown in Figure 1.

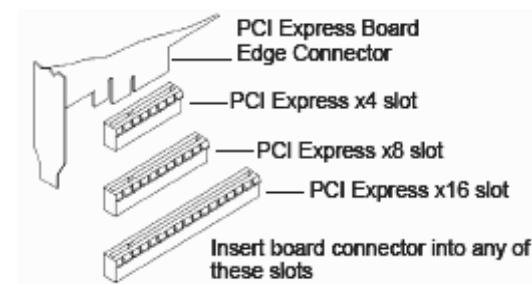

Figure 1. PCI Express Slots

## Connecting the Phone Service

The appropriate telephone service and hookups must be installed at your site in order to connect to telephone service.

Table 1 shows the relationship between channel and connector for each board configuration.

Table 1: Channel and Connector Relationship

TR1034+E4C (Two ALS and Two DID Channel Configuration)		
Channel Number	RJ-45 Connector	Type of Service
0	A	ALS
1	A	ALS
2	B	DID
3	B	DID
TR1034+E4D (Four DID Channel Configuration)		
0	A	DID
1	A	DID
2	B	DID
3	B	DID
TR1034+E2C (One ALS and One DID Channel Configuration)		
0	A	ALS
1	B	DID
TR1034+E2-2L (Two ALS Channel Configuration)		
0	A	ALS
1	A	ALS
TR1034+E2D (Two DID Channel Configuration)		
0	A	DID
1	A	DID

Use the cable supplied with the board. See Figure 2 for pinout details for your board.

Use the following instructions to connect your board to ALS or DID service.

1. Plug one end of the cable into the A or B RJ-45 telephone connector on the board (see Figure 3 and Figure 4 to locate connectors).
2. Plug the other end into the wall connector for your telephone service.

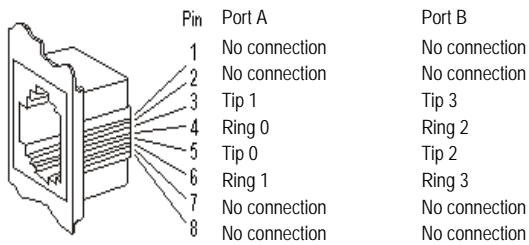

Port A = ALS or DID Port B = DID only

Figure 2. ALS and DID Connector Pinouts

Table 2 and Table 3 describe how the end panel LEDs provide information.

Table 2: Channel LEDs

Channel LEDs	Meaning
Off	Channel is on hook (inactive).
Flashing at 0.5 second rate	Channel is off hook (active).
Flashing at Ring Cadence (varies by country)	Incoming ring signal (ALS only).

Table 3: Board Status LED

Board Status LED	Meaning
Flashing yellow (1.5 second rate)	Board has successfully powered up and is ready for firmware.
Solid red	Board has failed power up tests.
Flashing yellow and green	Application is downloading firmware to the board.
Flashing green (1 second rate)	Firmware is downloaded, and the board is in service.
Solid green or Flickering red	Invalid states. Please reinstall your board and call Tech Support, if the condition persists.
Off	Board is not powered up.

## Using the TR1034 DID, Combo & Loop Start Board

Once you have installed your Dialogic® Brooktrout® TR1034 board, install and configure your fax or voice software application according to instructions included with the software.

## Getting Help

Dialogic provides technical support for customers who have purchased hardware or software products from Dialogic. If you purchased products from a reseller, please contact that reseller for technical support. This equipment contains no user serviceable parts and is not intended for repair by unauthorized personnel. If you experience problems with your TR1034 board, please use the contact information below for repair or warranty information. If the equipment is causing harm to the telephone network, the telephone company might request that you disconnect the equipment until the problem is resolved. To obtain technical support, please use the website : [www.dialogic.com/support](http://www.dialogic.com/support)

## Understanding LED Signals

### LEDs on the Mounting Bracket

The LEDs on the mounting bracket provide information about the status of the different systems on the board. To identify and locate these LEDs, see Figure 3.

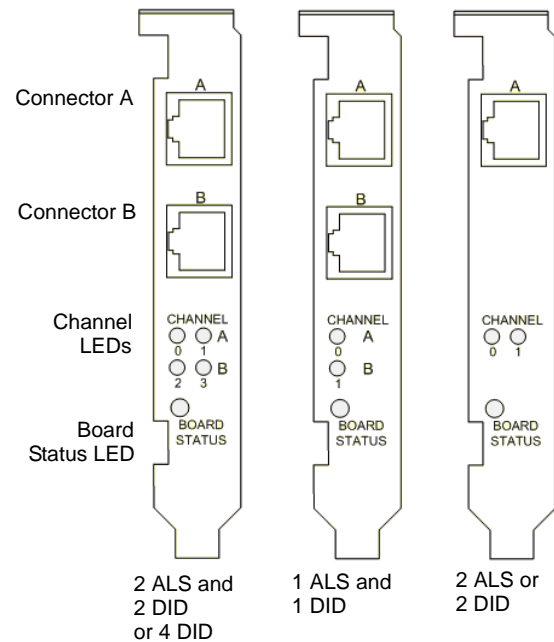

Figure 3. End Panel Connector and LEDs

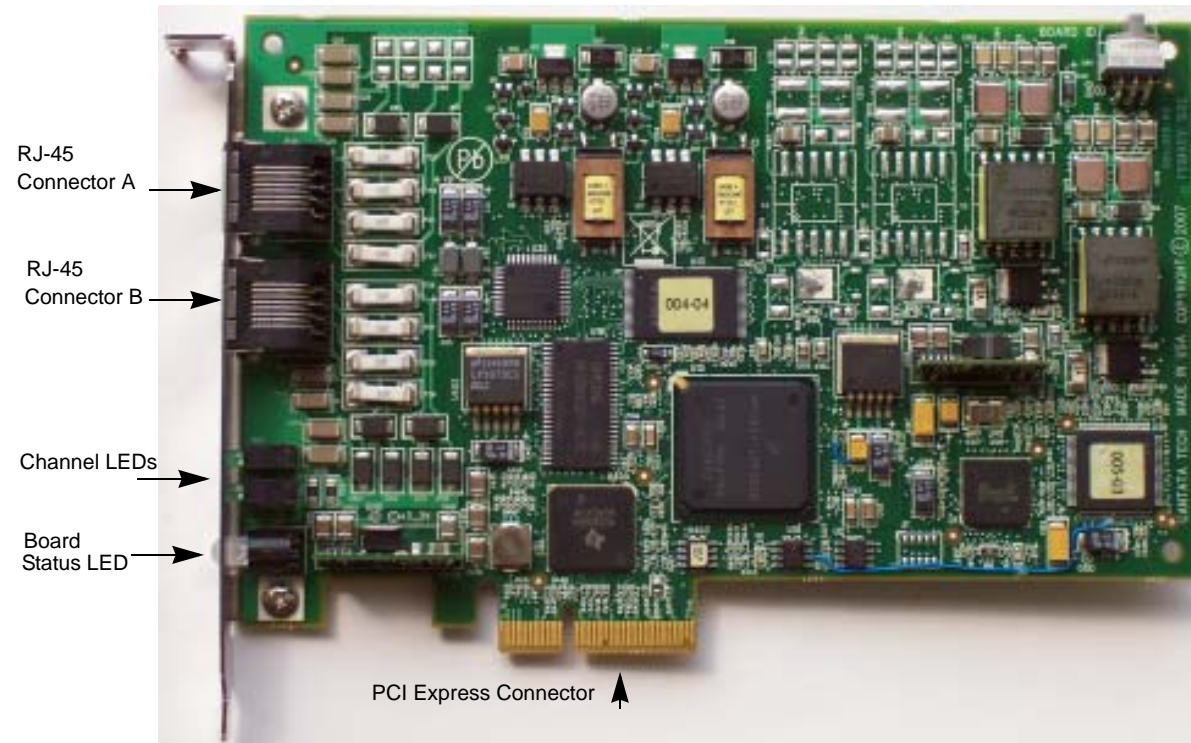

Figure 4. Dialogic® Brooktrout® TR1034 DID, Combo & Loop Start PCI Express Board

### Copyright and Legal Notice

Copyright © 2006-2008 Dialogic Corporation. All Rights Reserved. You may not reproduce this document in whole or in part without permission in writing from Dialogic Corporation at the address provided below.

All contents of this document are subject to change without notice and do not represent a commitment on the part of Dialogic Corporation or its subsidiaries. Reasonable effort is made to ensure the accuracy of the information contained in the document. However, due to ongoing product improvements and revisions, Dialogic Corporation and its subsidiaries do not warrant the accuracy of this information and cannot accept responsibility for errors or omissions that may be contained in this document.

INFORMATION IN THIS DOCUMENT IS PROVIDED IN CONNECTION WITH DIALOGIC® PRODUCTS. NO LICENSE, EXPRESS OR IMPLIED, BY ESTOPPEL OR OTHERWISE, TO ANY INTELLECTUAL PROPERTY RIGHTS IS GRANTED BY THIS DOCUMENT. EXCEPT AS EXPLICITLY SET FORTH BELOW OR AS PROVIDED IN A SIGNED AGREEMENT BETWEEN YOU AND DIALOGIC, DIALOGIC ASSUMES NO LIABILITY WHATSOEVER, AND DIALOGIC DISCLAIMS ANY EXPRESS OR IMPLIED WARRANTY, RELATING TO SALE AND/OR USE OF DIALOGIC PRODUCTS INCLUDING LIABILITY OR WARRANTIES RELATING TO FITNESS FOR A PARTICULAR PURPOSE, MERCHANTABILITY, OR INFRINGEMENT OF ANY INTELLECTUAL PROPERTY RIGHT OF A THIRD PARTY.

Dialogic products are not intended for use in medical, life saving, life sustaining, critical control or safety systems, or in nuclear facility applications.

It is possible that the use or implementation of any one of the concepts, applications, or ideas described in this document, in marketing collateral produced by or on web pages maintained by Dialogic Corporation or its subsidiaries may infringe one or more patents or other intellectual property rights owned by third parties. Dialogic Corporation or its subsidiaries do not provide any intellectual property licenses with the sale of Dialogic products other than a license to use such product in accordance with intellectual property owned or validly licensed by Dialogic Corporation or its subsidiaries. More detailed information about such intellectual property is available from Dialogic Corporation's legal department at 9800 Cavendish Blvd., 5th Floor, Montreal, Quebec, Canada H4M 2V9. The software referred to in this document is provided under a Software License Agreement. Refer to the Software License Agreement for complete details governing the use of the software.

Dialogic Corporation encourages all users of its products to procure all necessary intellectual property licenses required to implement any concepts or applications and does not condone or encourage any intellectual property infringement and disclaims any responsibility related thereto. These intellectual property licenses may differ from country to country and it is the responsibility of those who develop the concepts or applications to be aware of and comply with different national license requirements.

Dialogic, Dialogic Pro, Brooktrout, Cantata, SnowShore, Eicon, Eicon Networks, Eiconcard, Diva, SIPcontrol, Diva ISDN, TruFax, Realblocks, Realcomm 100, NetAccess, Instant ISDN, TRXStream, Exnet, Exnet Connect, EXS, ExchangePlus VSE, Switchkit, N20, Powering The Service-Ready Network, Vantage, Connecting People to Information, Connecting to Growth and Shiva, among others as well as related logos, are either registered trademarks or trademarks of Dialogic.